

18 x 18 x 4 mm Series

Rev. I

Dimensions

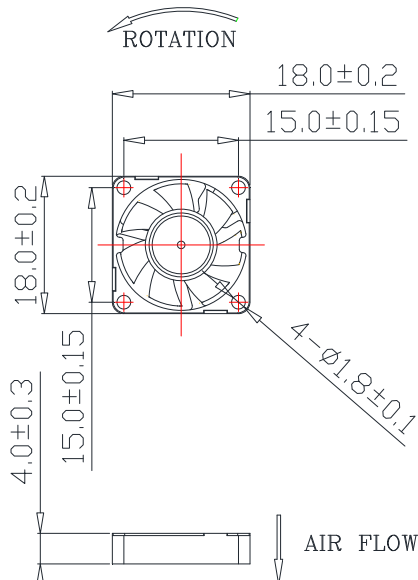

Performance Curve

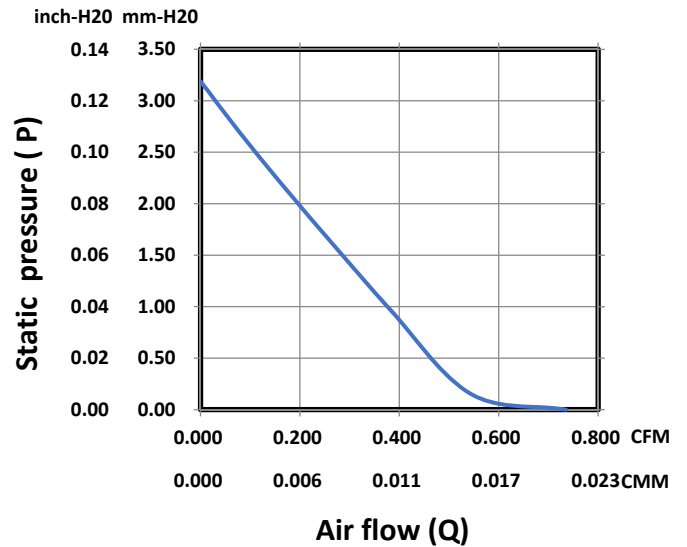

General Specification

Frame	PBT 94V-0
Impeller	PPS 94V-0
Lead Wire	UL10064 32AWG
Storage Temperature	-20°C ~ 80°C
Operating Temperature	-10°C ~ 75°C
Mass	2.2 gram

Bearing Type

- CeraDyna A
- CeraDyna C
- Ball Bearing
- Sleeve Bearing
- Fluid Dynamic Bearing

Function Options

- Auto Restart
- Frequency Generator
- Rotation Detect
- Temperature Control
- PWM Control

*Air exhaust over struts. Rotational direction CCW looking at rotor

*The motor is with electronic protection against reverse polarity. The motor only operates when the polarity is correct.

Specifications

Model No.	Rated Voltage (V)	Rated Current (A)	Input Power (W)	Nominal Speed (RPM)	Airflow (CFM)	Static Pressure (Inch-H2O)	SPL (dB A)
FD0518-S00XXR	5	0.07	0.35	13000	0.73	3.14	28.5

*All readings are typical value at rated voltage.

*Please refer to **PART NUMBER SYSTEM** for bearing type and part number "XX" designation.

*Please specify revision number when ordering.